

Section Details of Shallow well

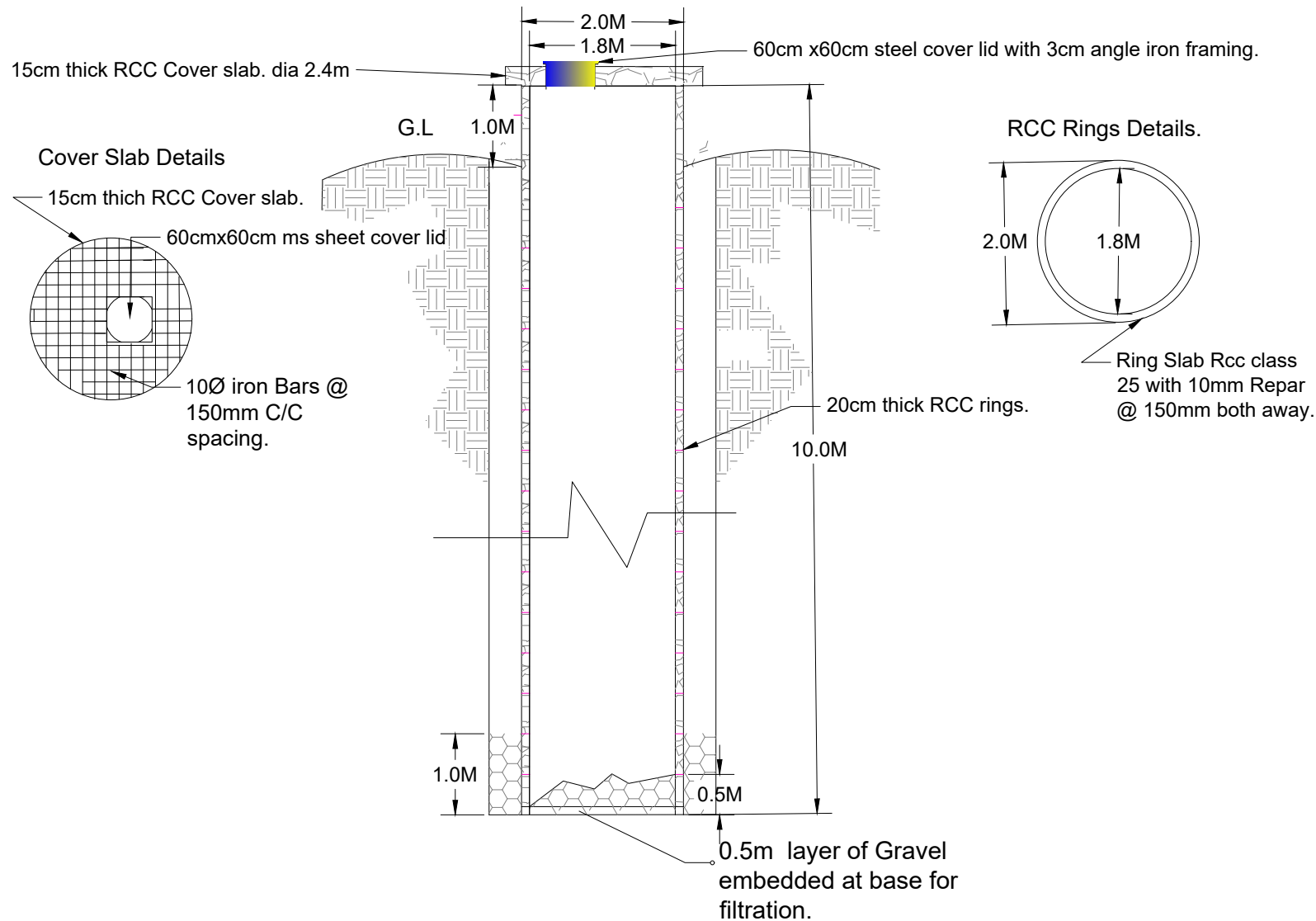

Taakulo Somali
Community

Drawing Title:

Drawn By:

Eng. shuab

Donor:

Danish Muslim Aid
[DM-AID]

Location:

Dhadhinyahye,
Ceelafwayn.

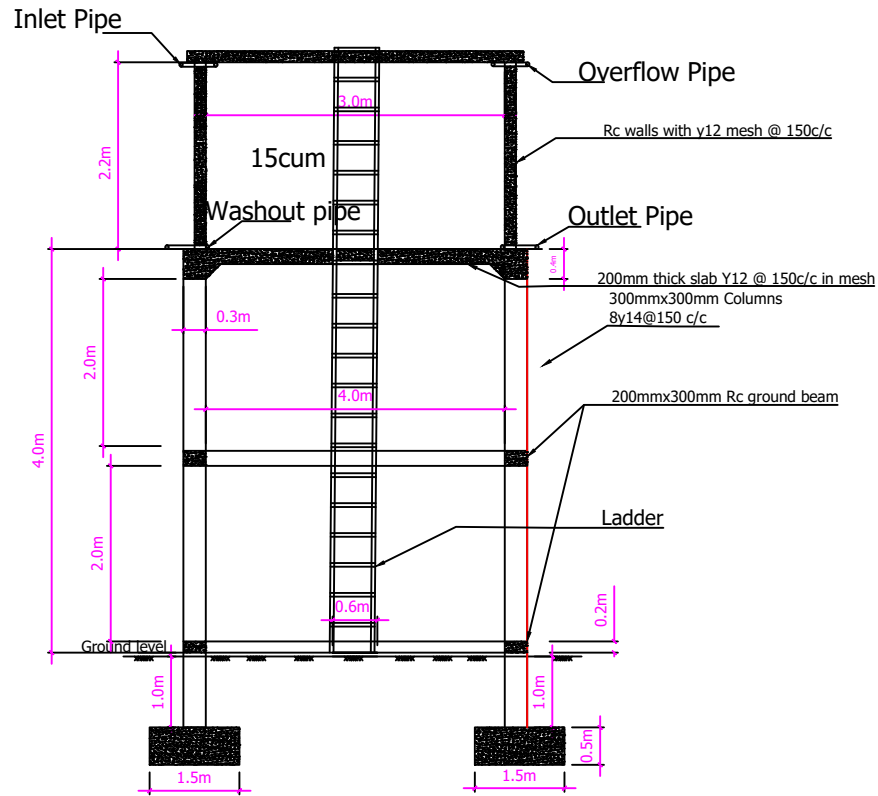

Tank Section

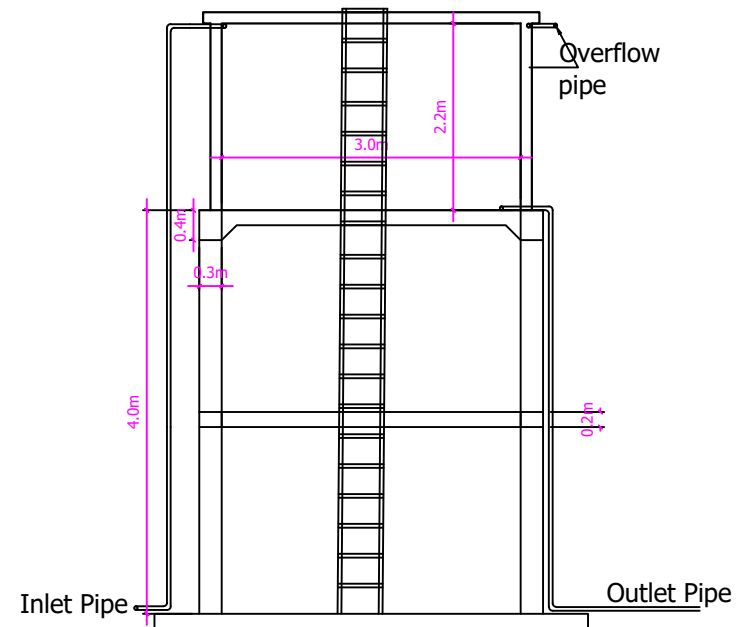

General Notes:

1. All dimensions are in meters unless specified.
2. The drawings should be read in conjunction with
3. the bill of quantities for more clarity.



TAAKULO
SOMALI COMMUNITY

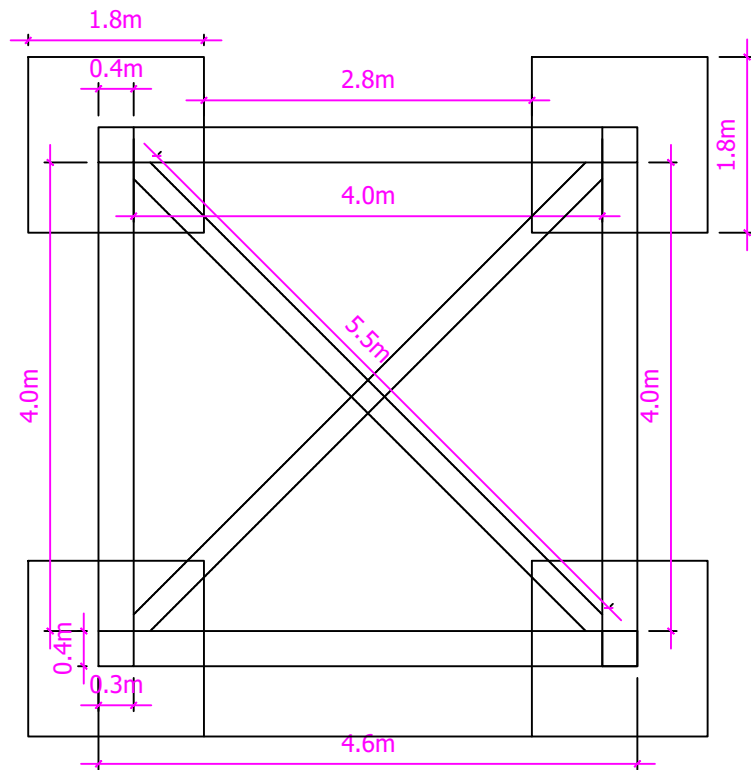

Footings Plan

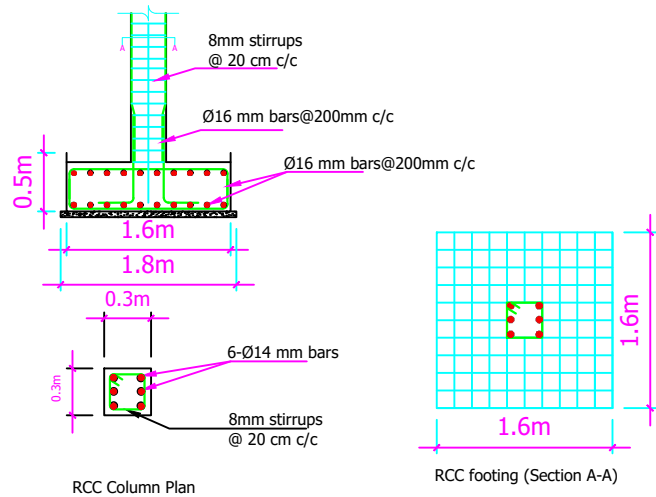

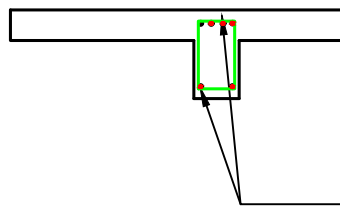

Beam section

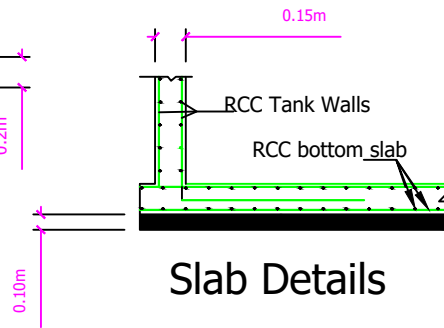

Slab Details

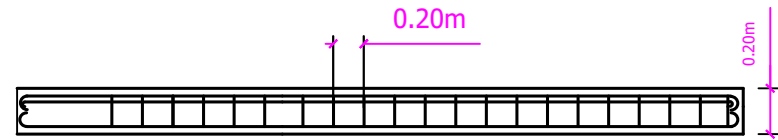

Longitudinal section of the beam under bottom slab

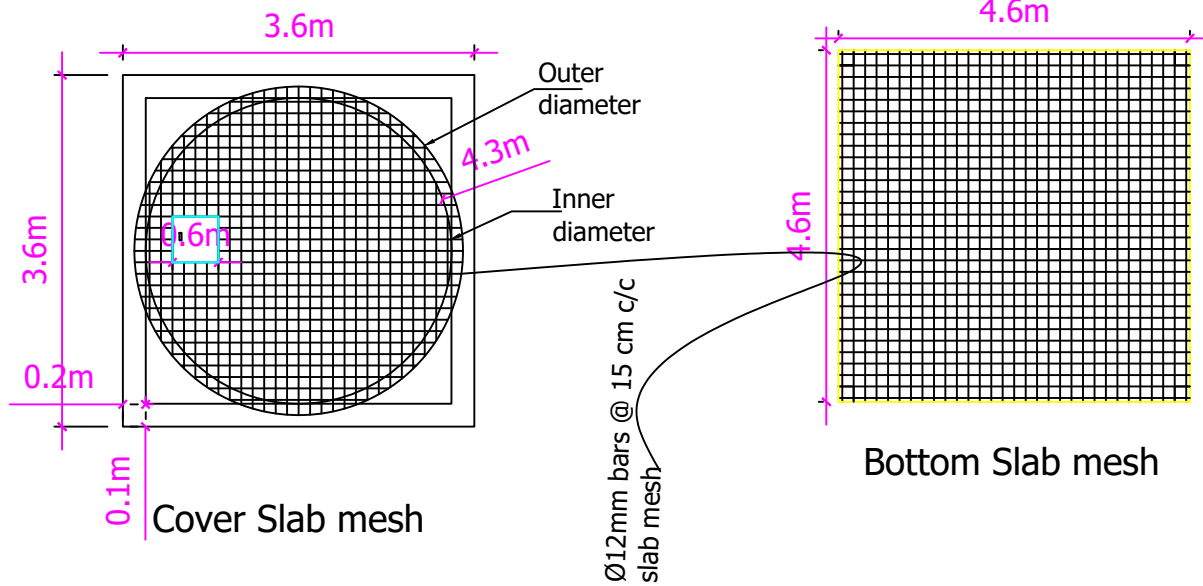

Cover Slab mesh

Bottom Slab mesh

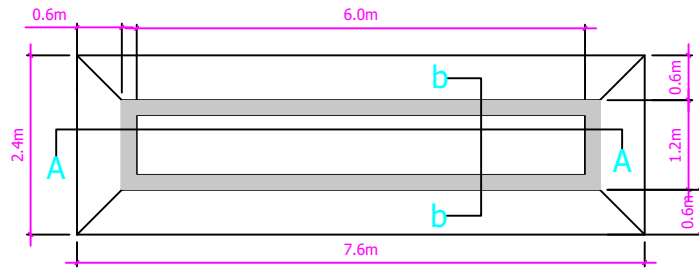

Camel trough plan

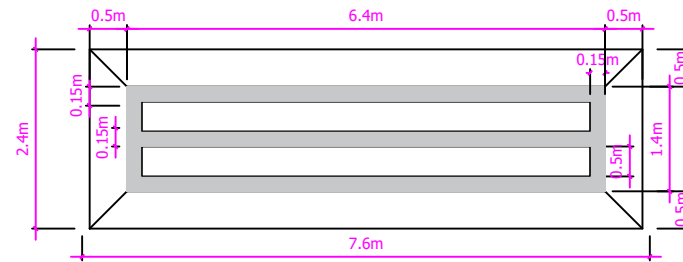

Shoats trough plan

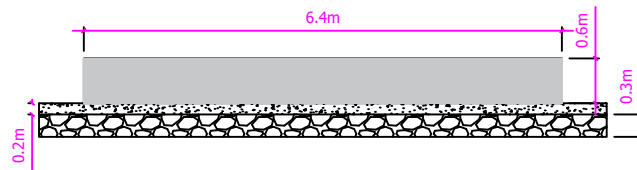

Camel trough sections a-a

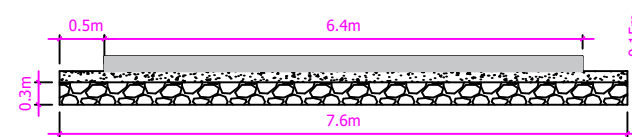

Shoats trough sections a-a

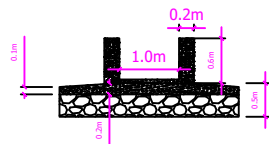

Camel trough sections b-b

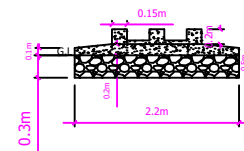

Camel trough sections b-b

Water point Plan and sections

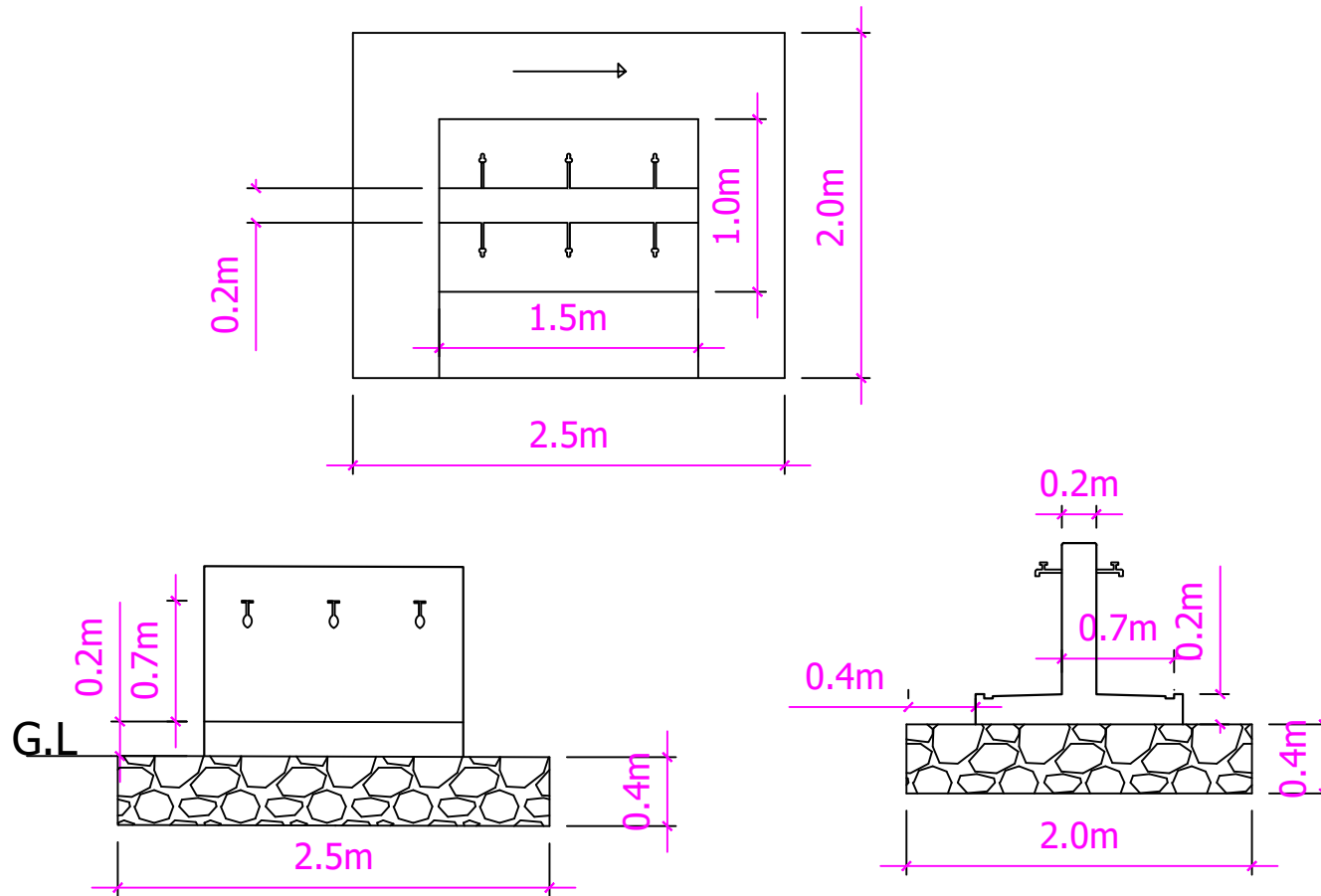

General Notes:

1. All dimensions are in meters unless specified.
2. The drawings should be read in conjunction with the bill of quantities for more clarity.
- 3.